

# YAODE TECHNOLOGY CO., LIMITED

## SPECIFICATION

For

Lithium ion polymer rechargeable battery

Customer : \_\_\_\_\_

Cell's model name : LP456770

Assembly : \_\_\_\_\_

Date : 2010-12-23

REVISED : V1.0

Customer approval

Comment :

Customer's signature/ Date : \_\_\_\_\_

Approved	Cheched	Prepared

## REVISION AND UPDATES

REVISED	DESCRIPTION	Date

# Contents

1. **Battery Type and Model**
  - 1.1 **Battery Type**
  - 1.2 **Battery Model**
  - 1.3 **Battery Outer Dimension**
2. **Performance**
3. **Electrical Characteristics**
  - 3.1 **Fully Charge**
  - 3.2 **Capacity**
  - 3.2 **Cycle Life**
  - 3.4 **Temperature**
  - 3.5 **Full Charged State Storage**
  - 3.6 **Full Discharged State Storage**
4. **Safety Performance**
  - 4.1 **High Temperature Storage**
  - 4.2 **Leak Test**
  - 4.3 **Drop-Test**
  - 4.4 **Vibration Test**
5. **Appearance**
6. **Cell condition at the shipment**
7. **Protection Circuit Characteristics**
  - 7.1 **Electrical Characteristic**
  - 7.2 **Bill of Materials**
  - 7.3 **PCB Pad description**
  - 7.4 **Application Circuit**
8. **Pre-charging Method**
9. **Safety Instruction**
10. **Performance Curves**
  - 10.1 **Charge & Discharge Performance**
  - 10.2 **Cycle Life Curves**
  - 10.3 **Discharge Curves**
11. **Pack Drawing**
  - 11.1 **Soft pack drawing**
  - 11.2 **BOM of Product**
12. **Danger**
13. **Warning**
14. **Caution**

# 1. Cell Type and Model

1.1 Cell Type : Lithium Ion Polymer Battery

1.2 Cell Model : LP456770

1.3 Cell Outer Dimension:  $4.5 \pm 0.2$  (T) X  $77.0 \pm 0.5$  (W) X  $70 \pm 1.0$  (L) mm

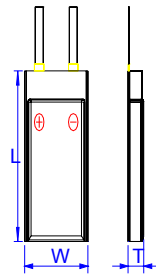

## E- Performance

Item		Specification	Remark
2.1	Nominal Capacity	2400mAh	0.2C discharge
	Minimum Capacity	2100mAh	
2.2	Nominal Voltage	3.7V	
2.3	End Voltage	2.75V	
2.4	Charging Current (Std.)	0.2CA(=480mAh)	Ambient temperature 0~+40
2.5	Charging Current (Max.)	1CA(=2400mA)	Ambient temperature 0~+40
2.6	Charge Method	CC/CV	
2.7	Charging Voltage	4.2±0.03V	
2.8	Charging Time (Std.)	6~7.0 hours	
2.9	Charging Time (Max.)	2~3.0 hours	
2.10	Discharging Current (Std.)	0.2CA	Ambient temperature -20~+60
2.11	Discharging Current (Max.)	1CA	Ambient temperature -20~+60
2.12	Internal Resistance	<140mΩ	AC Impedance 1KHz
2.13	Weight	49g	
2.14	Temperature range for storage	less than 1 month	Percentage of recoverable capacity 80 %
		less than 3 month	
		less than 1 year	

□(1).Percentage of recoverable capacity

$$=(\text{discharging time after storage} / \text{discharging time Initial}) \times 100 \%$$

(2).Discharging time is estimated by the discharge at 0.2CA to end voltage 2.75V after fully charged according to specification at approximately 25□.

## E- Electrical Characteristics

Item	Test Method	Criterion
3.1 Fully Charge	(1)Standard Charge: Supply 0.2C constant current until battery voltage reaches 4.2V, then supply a decreasing current endlessly. Charging time is 6~7 hours. (2)Quick Charge: Supply 1.0C constant current until battery voltage reaches 4.2V, then supply a decreasing current endlessly. Charging time is 2~3 hours.	Ambient temperature 0 ~+40℃
3.2 Capacity	(1)Within 1 hour after fully charged, discharge at 0.2C continuously down to end voltage 2.75V. (2)Within 1 hour after fully charged, discharge at 0.5C ( =1200mA ) continuously down to end voltage 2.75V.	more than 300 min (100%) more than 108 min (90%)
3.3 Cycle Life	(1)A battery unit shall be repeated 410 charge/discharge cycles, charged at CC-CV ( 0.2C to 4.20 V ) for 6~ 7 hours, discharged at 0.2C to 2.75V end voltage, After 410 cycles, discharging time is estimated as specified in paragraph 3.2(2)	more than 36 min (60%)
3.4 Temperature	(1)Within 1 hour after fully charged at 20℃, a battery unit is stored at -20℃. Discharge time is estimated by discharging at 0.5C continuously down to 2.75V end voltage. (2)Within 1 hour after fully charged at 20℃, a battery unit is stored at 60℃. Discharge time is estimated by discharging at 0.5C continuously down to 2.75V end voltage.	More than 50 min (65%) more than 102 min (85%)
3.5 Full Charged State Storage	(1)After fully charged, stored for 10days at 60℃ and rested at room temperature for 1 hour. Discharge time is estimated by discharging at 0.5C continuously down to 2.75V end voltage. (2)Then next discharge time is estimated as specified in paragraph 3.2(2).	More than 84 min (70%) more than 96 min (80%)
3.6 Full Discharged State Storage	(1) After fully charged, discharge as specified in paragraph 3.2(2), then store for 10 days at 60℃ and rest at room temperature for 1hour. Discharging time is estimated as specified in paragraph 3.2(2).	More than 90 min (75%)

## 4. Safety Performance

Item	Test Method	Criterion
4.1 High Temperature Storage	After fully charged, store for 10 days at 60℃.	No rupture, fire , smoke or swell and leakage of liquid electrolyte apparently

4.2 Leak Test	After fully charged, store for 10 days at 60□ and at humidity 70±20 % .	No rupture, fire , smoke or swell and leakage of liquid electrolyte apparently
4.3 Drop-Test	The battery is dropped 3 times for three-dimensional face of the battery (total of 9 times dropping) from a height of 76cm on the hard wooden board.	There shall be no abnormal performance and structure or excessive deformation.
4.4 Vibration Test	Vibrate for 60 minutes to any direction with amplitude 4mm and frequency 16.7Hz.	There shall be no abnormal performance and structure or excessive deformation.

## 5. Appearance

There shall be no practical damage such as conspicuous liquid leakage, flaw, rust, dirt, swell, and deformation.

## 6. Cell capacity condition at the shipment

About 20~50 % charged state.

## 7. Protection Circuit Characteristics (at 25□)This specification item is option.

### 7.1 Electrical Characteristic

Item	Symbol	Content	Criterion
Over charge Protection	VDET1	Over charge detection voltage	4.3± 0.05V
	tVDET1	Over charge detection delay time	1.2±0.2s
	VREL1	Over charge release voltage	4.08±0.035V
Over discharge protection	VDET2	Over discharge detection voltage	3.0±0.05V/cell
	tVDET2	Over discharge detection delay time	144±29ms
Over current protection	VDET3	Over current detection voltage	80±15mv
	IDP	Over current detection current	2.5±1A
	tVDET3	Detection delay time	9±2ms
		Release condition	Cut load
Short protection		Detection condition	Exterior short circuit
	TSHORT	Detection delay time	80—380us
		Release condition	Cut short circuit
Interior resistance	RDS	Main loop electrify resistance	VC=4.2V ; RDS≤60mΩ
Current consumption	IDD	Current consume in normal operation	3.5μA Type 7.0μA Max

### Bill of Materials

NO.	Location	Part name	Specification	PackType	Q'ty	Maker/Remark
-----	----------	-----------	---------------	----------	------	--------------

1	U1	Battery protection IC	S8261 G3J	SOT-23-6	1	SEIKO
2	U2	Silicon MOSFET	D2017		1	SANYO
3	R1	Resistance	SMD 470Ω±5%	0402	1	YAGEO
4	R2	Resistance	SMD 1KΩ±5%	0402	1	YAGEO
5	R3		SMD 10KΩ±5%	0402	0	E-WAY
6	C1	Capacitance	SMD 0.1μF	0402	1	SAMSUNG
7	T	NTC	10 KΩ±5% (B=3435)	0402	1	
8	PCB	Print circuit board	0.6*3.6*16mm(±0.15mm)	FR4	1	WHITE OIL/GILD

### 7.3 PCB Pad description

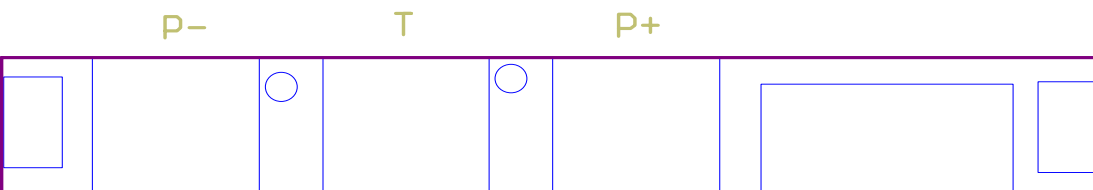
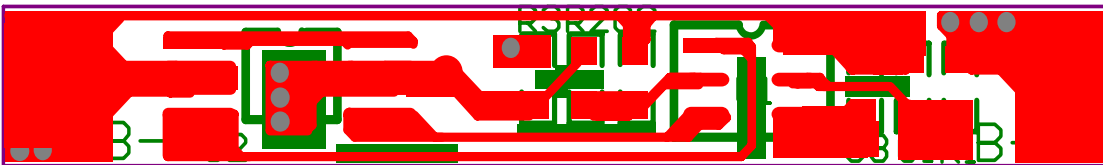
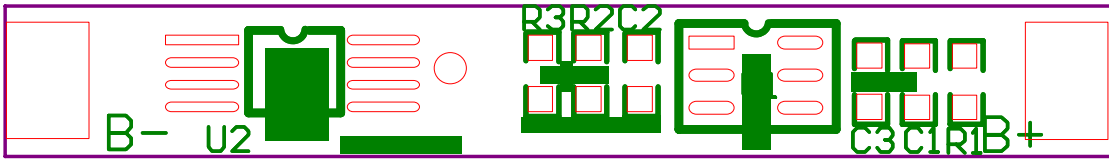

### 7.4 Application Circuit



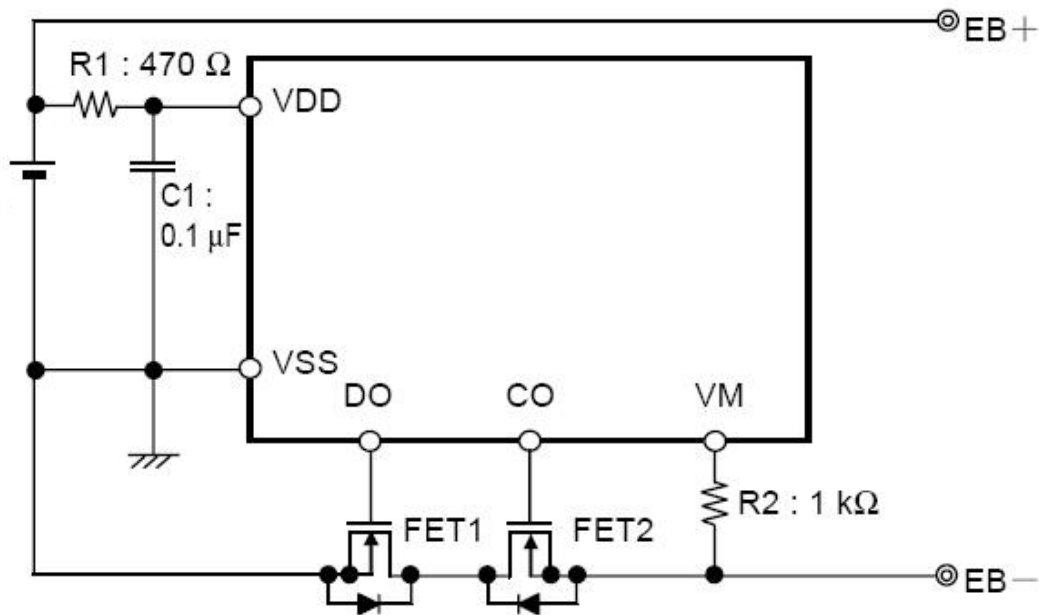

## 8. Pre-charging Method

(1) It's possible that the battery voltage decreases about 0V by the storage. If that battery is rapid-charged, there is much possibility that the temperature of the FET is growing highly.

The charger must have the pre-charge system in consideration of the drop of battery voltage.

(2) Pre-charge current of charger is approximately 0.2C. When the battery voltage becomes 3.0V, standard charge start. If the battery voltage never reach to 3.0V in specified of the time clock, charging turns off.

(3) Standard charge method is 0.2C~4.20V(Constant current-constant voltage). Charging turns off when the specified condition of time clock, current, or O.C.V. is satisfied.

## 9.Safety Instruction

The battery pack includes the flammable objects such as the organic solvent. If the handling is missed, there will be possibility that the battery rupture, Flames or hot, or it will cause the deterioration or damage of battery. Please observe the following prohibitive matters. And the protection Device the equipment for fear that the trouble would affect the battery by the Abnormality of equipment. In addition the following matters as "Prohibition Points on Handle" in the instruction manual of the equipment.

# 10. Performance Curves

## 10.1 Charge & Discharge Performance

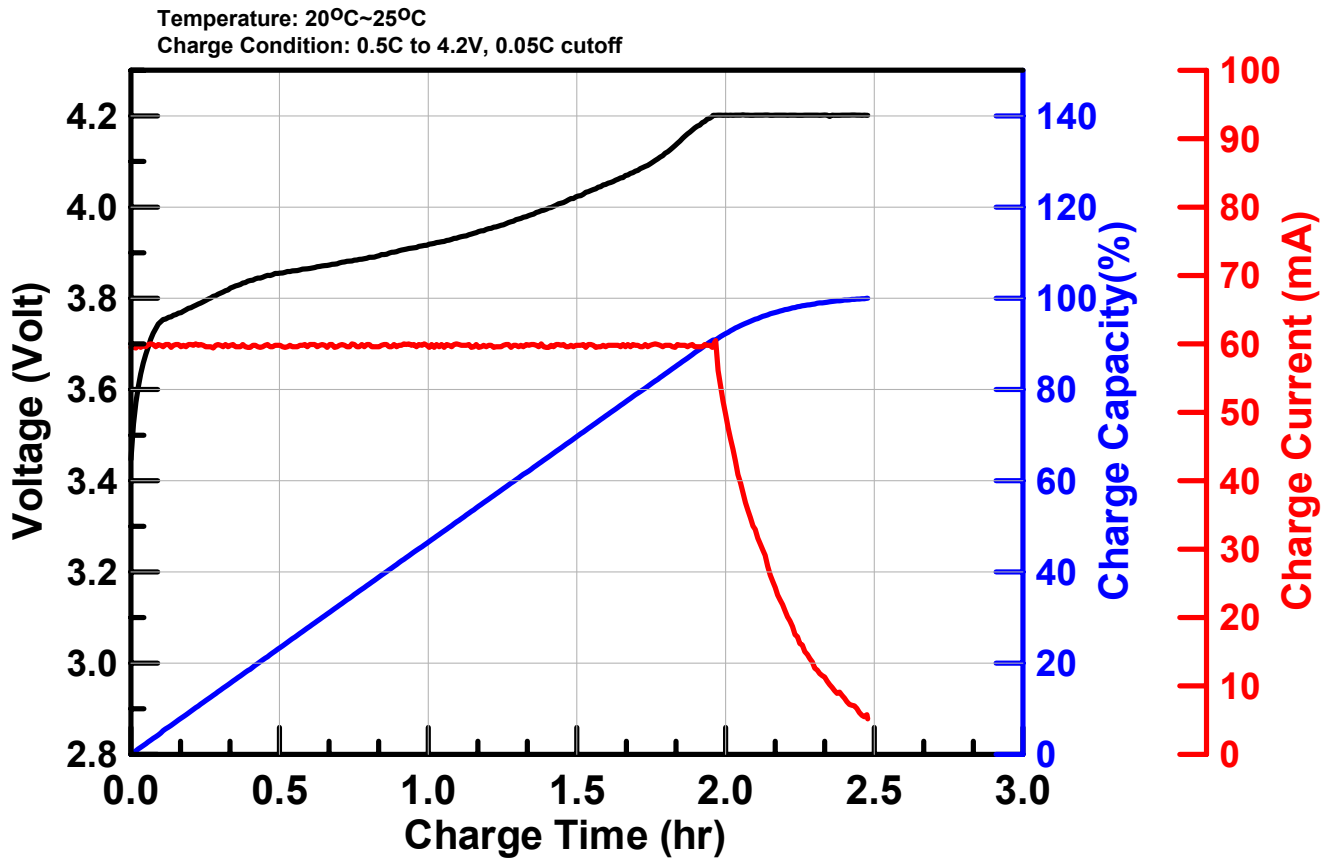

## 10.2 Cycle Life Curves

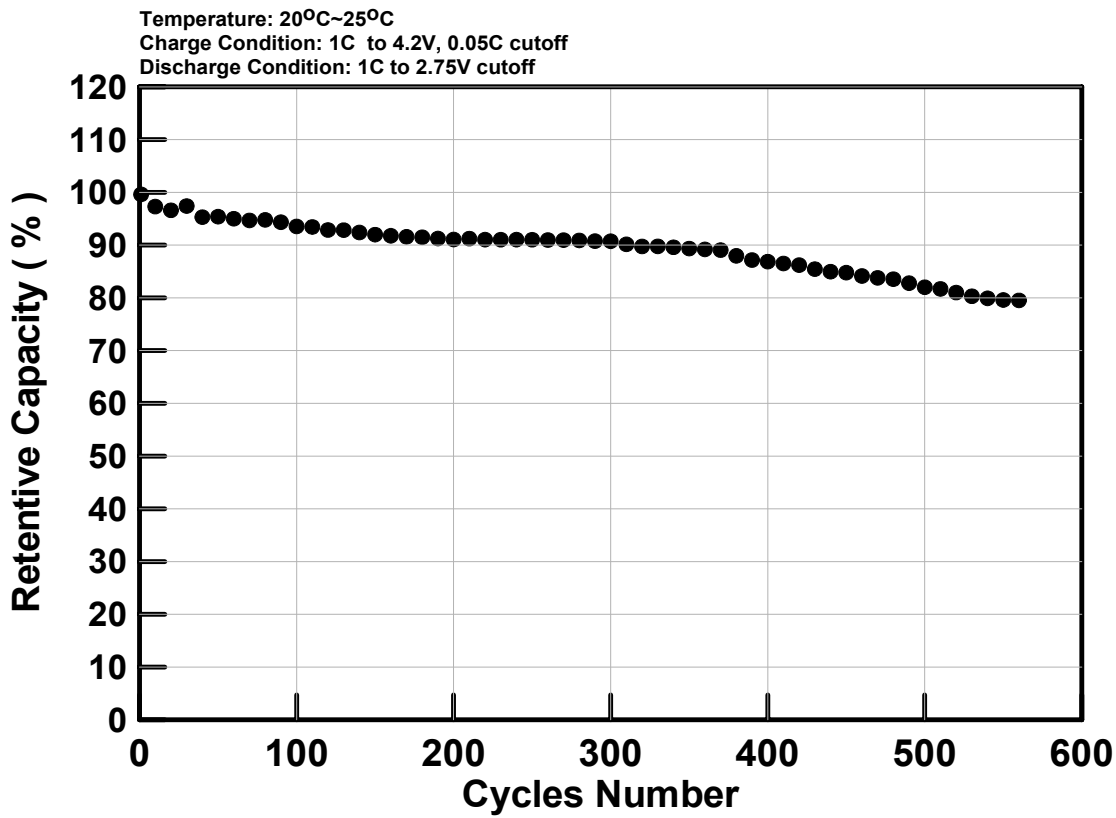

### 10.3 Discharge Curves

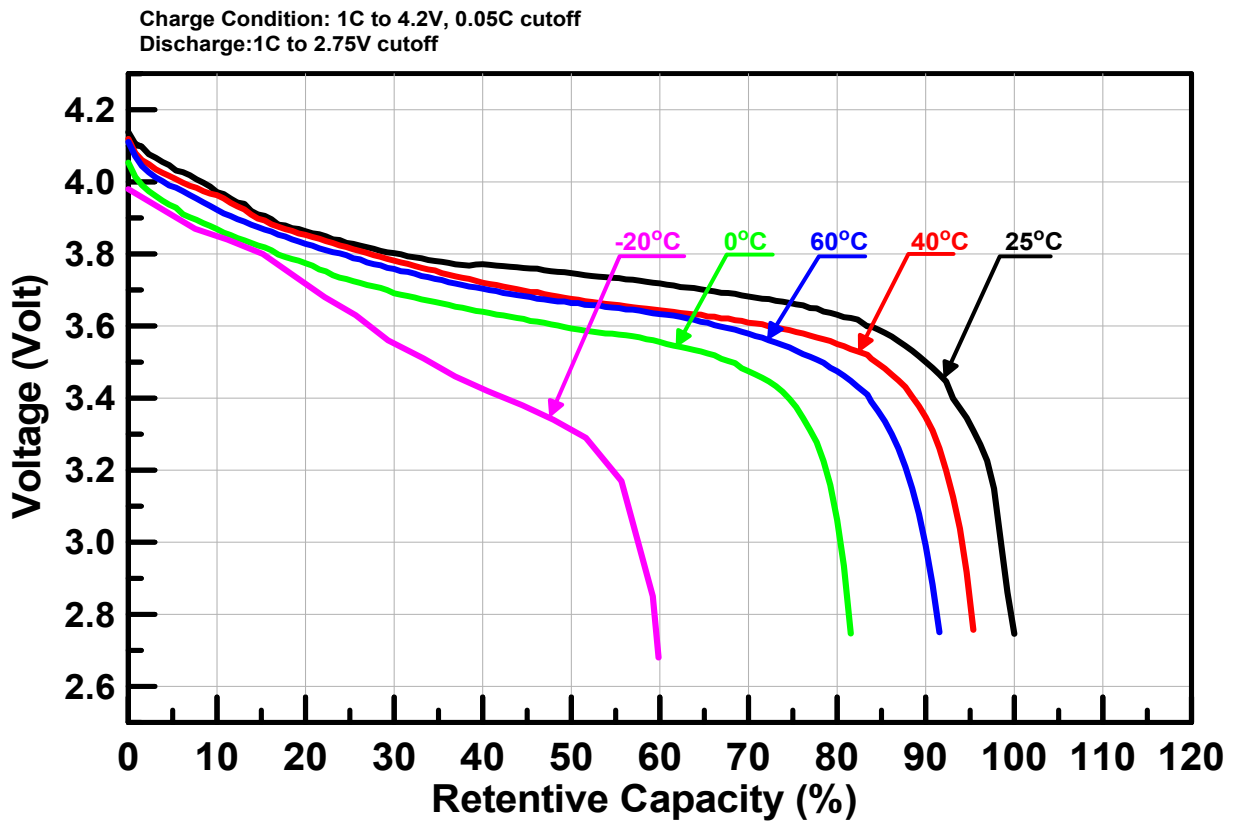

### 11.Pack Drawing

**11.1 Soft pack drawing (Product Outer Dimension(Max):4.6(T) X67.5(W) X71(L) mm  
L1=60±3mm.**

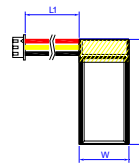

**11.2 BOM of Product**

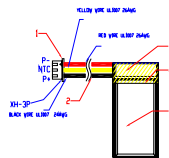

	Item	Model	Specification	Remarks
1	CONNECTOR	MOLEX	XH-3P	
	Wire		AWG 24# UL1007	
2	PCM	Li-ion single cell PCM		See Table
3	Tape	Kapton		
4	Cell	LP 456770		

## 2. Danger !

### 1,Disassemble and Reconstruction

“Do not disassemble or reconstruct battery”

The battery has safety function and protection circuit to avoid the danger. If they have serious damage, it will cause the generating, smoke, rupture or flaming.

### 2,Short-circuit

“Do not short-circuit battery”

Do not connect the + and – terminals with metals (such as wire). Do not carry or store the battery with metal objects (such as wire, chain , necklet or hairpins). If the battery is short-circuited, excessive large current will flow and then the generating, smoke, rupture or flaming will occur. And also, it causes generating of metals.

### 3,Use nearby Heated Place

“Do not use or leave battery nearby fire, stove or heated place(more than 80 )”

In case that separator made of polymer is melted by high temperature, the internal short-circuit occurs in individual cells and then it causes the generating, smoke, rupture or flaming. In addition, do not use the battery under the heated pace (more than 80□) for same reason.

### 4,Immersion

“Do not immerse the battery in water or sea water , or get it wet”

If the protection circuit included in the battery is broken, the battery will be charged at extreme current or voltage and the abnormal chemical reaction occurs in it. And then it causes the generating, smoke, rupture or flaming.

### 5,Charge nearby heated place

“Do not charge battery nearby the fire or under the blazing sun”

If the protection circuit to avoid the danger works under high temperature or it is broken, the battery will be charged at abnormal current (or voltage) and abnormal chemical reaction will occur. It causes the generating, smoke, rupture or flaming.

### 6,Charger and Charge Condition

“Do use the specified charger and observe charging requirement”

If the battery is charged with unspecified condition (under high temperature over the regulated value, excessive high voltage or current over regulated value, or remodeled charger). There are cases that it will be overcharged or the abnormal chemical reaction will occur in cells. It causes the generating, smoke, rupture or flaming.

### 7,Penetration

“Do not drive a nail into the battery. Strike it by hammer, or tread it”

As the battery might be broken or deformed and then it will be short-circuited, It causes the generating, smoke, rupture, or flaming.

## 8,Impact

“Do not give battery impact or fling it”

If the protection circuit assembled in the battery is broken, the battery will be Charged at abnormal voltage or current and abnormal chemical reaction will occur. It causes the generating, smoke, rupture or flaming.

## 9,Soldering

“Do not make the direct soldering on battery”

It causes the generating, smoke or flaming.

## 10,Reverse Charge and Overdischarge

“Do not make the direct soldering on battery”

On charging, the battery is reverse-charged and abnormal chemical reaction occurs. And also, there may be case that unexpected large current flows on discharging. These cause the generating, smoke, rupture or flaming.

## 11. Reversed Polarity Use

*“Do not reverse-charge or reverse-connect”*

The battery has polarity. If the battery is connected to opposite polarity with charger, it will generating, smoke, rupture or flaming.

## 12.Connect Battery To the Plug

“Do not connect battery to the plug socket or car-cigarette-plug”

Added high voltage to the battery, the excessive current will flow in it and then it will cause the generating, smoke, rupture or flaming.

## 13.Inappropriate Use For unspecified Equipment

*“Do not use battery for unspecified equipment”*

If the battery is used for unspecified equipment, it will deteriorate its performance and cycle-life. At worst, abnormal current will flow or battery may generate, smoke, rupture or flame.

## 14.Leakage

“Do not touch a leaked battery directly”

In case the leaked electrolyte gets into eyes, wash them with fresh water as soon as possible without rubbing eyes. And then, see a doctor immediately. If leave damaged eyes undone, it will cause eye-trouble.

## 13. Warning !

### 1, Mixed Use

“Do not use Lithium ion battery in mixture”

Do not use Lithium ion battery with the primary batteries or secondary batteries whose capacity kind or maker is different, if do that, the battery will be discharged or charged excessively in use. And it may cause the generating, smoke, rupture or flaming because of the abnormal chemical reaction in cells.

### 2, Ingestion

“Keep the battery away from babies”

Keep the little battery out of the reach of babies in order to avoid troubles by swallowing. In case of swallowing the battery, see a doctor immediately.

### 3, Charging Time

“Do not continue to charge battery over specified time”

If the battery is not finished charging over regulated time, let it stop charging. There is possibility that the battery might generate, smoke, rupture or flame.

### 4, Store

“Do not get into a microwave or a high pressure container”

It causes the generating, smoke, rupture or flaming because of a sudden heat or damage of sealing condition of battery.

### 5, Leakage

“Do not use a leaked battery nearby fire”

If the liquid leaks from the battery (or the battery gives out bad smell), let the battery leave from flammable objects immediately. Unless do that, the electrolyte leaked from battery will catch fire and it will cause the smoke, flaming or rupture of it.

### 6, Rust, Changing color and Deformation

“Do not use an abnormal battery”

In case the battery has bad smell, it generates, its color changes or it is warped in using (includes charging and storage), let it take out from equipment or charger and do not use it. If an abnormal battery is used, it will generate, smoke, rupture or flame.



## 14. Caution !

### 1. Use under strong sunshine

Do not use or leave the battery under the blazing sun(or heated car by sunshine). The battery may smoke, heat or flame. And also, it might cause the deterioration of battery's characteristics or cycle life.

### 2. Static Electricity

The battery has the protection circuit to avoid the danger. Do not use nearby the place where generates static electricity (more than 100V) which gives damage to the protection circuit. If protection circuit were broken, the battery would generate, smoke, rupture or flame.

### 3. Charging Temperature Range

Charging temperature range is regulated 0°C and 60°C. Do not charge the battery out of recommended temperature range. Charging out of recommended range might cause the generating or serious damage of battery. And also, it might cause the deterioration of battery's characteristics and cycle life.

### 4. Manual

Please read the manual before using the battery

### 5. Charging Method

Please read the manual of specified charger about charging method.

### 6. First time use

When the battery has rust, bad smell or something abnormal at first-time-using, do not use the equipment and go to bring the battery to the shop which it was bought.

### 7.Used by children

In case younger children use the battery, their parents teach how to use batteries according to the manual with care. And also, when children are using the batteries, pay attention to use it according to that or not.

### 8.Keep Battery away from children

Keep the battery out of the reach of younger children. And also, using the battery, pay attention to be taken out it from the charger or equipment by little children.

### 9.Leakage

If the skin or cloth is smeared with liquid from the battery, wash with fresh water. It may

cause the skin inflammation.

## 10. Consultation

If there's any problem about the battery , contact the following

## 11. Warranty Period of Battery

The warranty period of battery is a one year from the date of shipment. However, even though the problem occurs within this period, YAODE won't replace a new battery for free as long as the problem is not due to the failure of YAODE manufacturing process or is due to customer's abuse or misuse.